



PTH 60

Collet Attachment Tooling System - Precision Turning Heads



HMETRADING AG

Im Obersteig 14
CH-8840 Einsiedeln
Tel +41 55 412 58 60
Fax +41 55 412 58 32
Homepage www.hmeag.ch

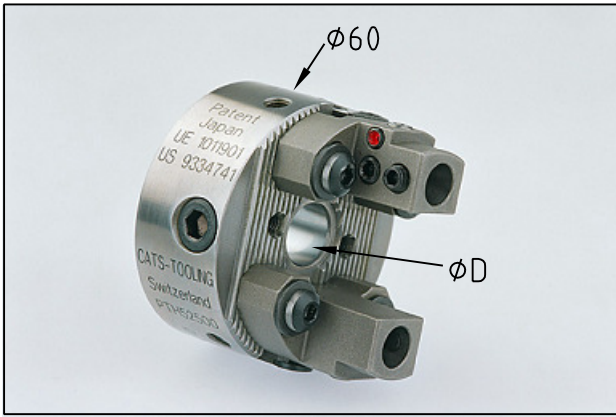

Precision Turning Head PTH 602

CATS NR.	D	Adaptor	L	Execution	Option
60201	12	M4.5x1	4.6	2+2 Holder	Adjustable balance ring $\phi 75$
60205	12	M50x15	4.6	2+2 Holder	Adjustable balance ring $\phi 75$

Radial adjustment : 7mm
 Axial adjustment : 6mm
 Center height adjustment : ± 0.5 mm

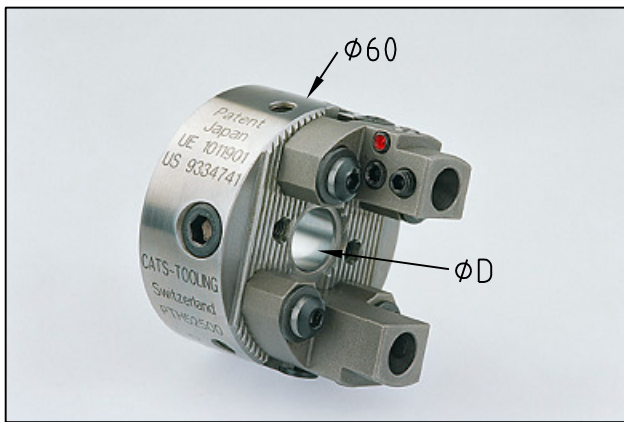

Precision Turning Head PTH 603

CATS NR.	D	Adaptor	L	Execution	Option
60301	12	M4.5x1	4.6	3 Holder	Adjustable balance ring $\phi 75$
60305	12	M50x15	4.6	3 Holder	Adjustable balance ring $\phi 75$

Radial adjustment : 7mm
 Axial adjustment : 6mm
 Center height adjustment : ± 0.5 mm

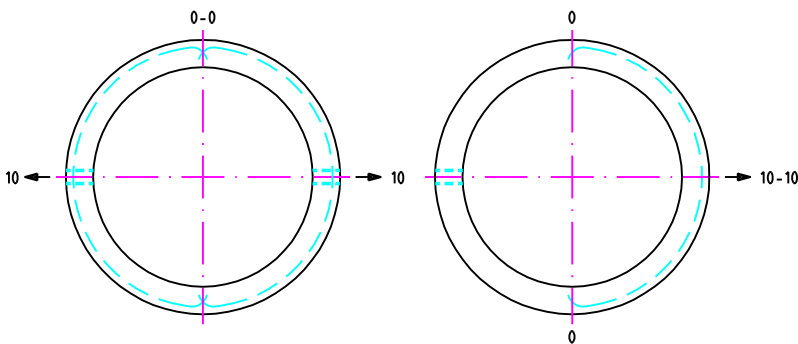

Adjustable balance ring

CATS NR.	D	E	F	R	G max. mm ³	For Heads CATS-PTH Nr.
60291	60	75	16	33	6200	60201,60205,60301,60305

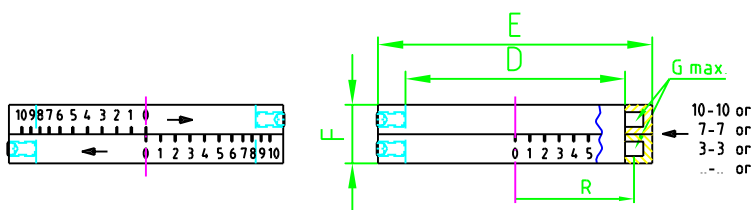

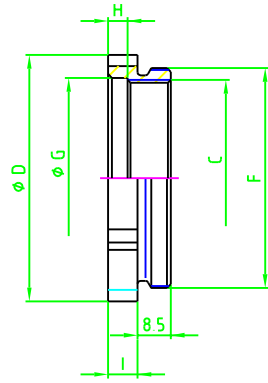
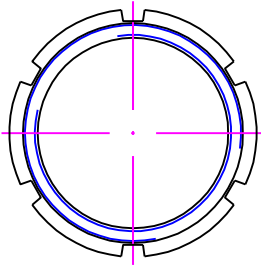

Interchangeable high power clamping nuts (DIN 6499)

CATS NR.	C	D	F	G	H	I	For CATS Heads
52500-21	M40x15	50	M45x1	40.5	4.5	7	PTH 602/603
52500-22	M32x15	50	M45x1	40.5	4.5	7	PTH 602/603
52500-23	M25x15	50	M45x1	40.5	4.5	7	PTH 602/603
52500-24	M22x15	50	M45x1	40.5	4.5	7	PTH 602/603
52500-25	M30x1	50	M45x1	40.5	4.5	7	PTH 602/603
52500-26	M24x1	50	M45x1	40.5	4.5	7	PTH 602/603 (Rego/Schaublin)

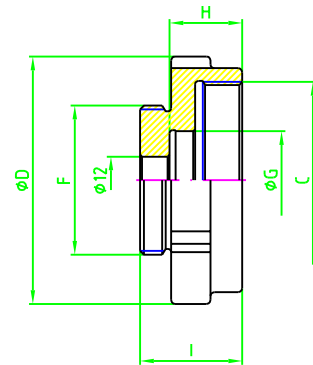
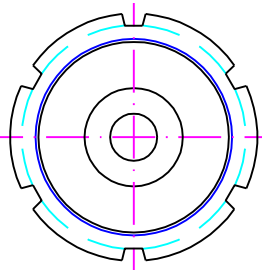

Special adaptor nut

CATS NR.	C	D	F	G	H	I	For CATS Heads
60500-21	M50x15	63	M45x1	25	18.5	26	PTH 602/603 Hydromat VE30/60
60500-22	M40x15	63	M45x15	16	15	23	PTH 602/603 Hydromat VE20/50

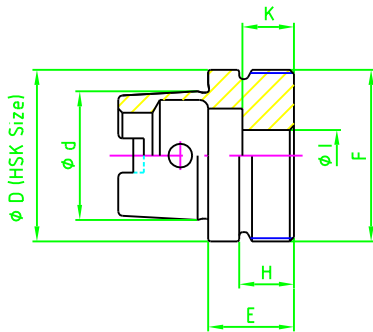

Spindle adaptor DIN-HSK (exchangeable execution)

CATS NR.	D	d	E	F	H	I	K	For CATS Heads
94132	32	24	20	M32x15	14	12	32	PTH 60
94140	40	30	20	M40x15	14	12	32	PTH 60

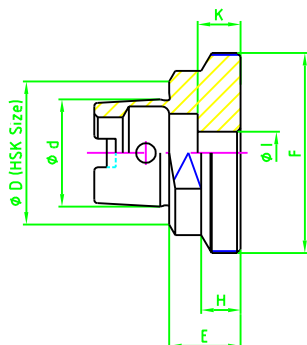

Spindle adaptor HSK

CATS NR.	D	d	E	F	H	I	K	For CATS Heads
94332	32	24	20	M45x1	11	12	12	PTH 60
94240	40	30	20	M45x1	10	12	12	PTH 60

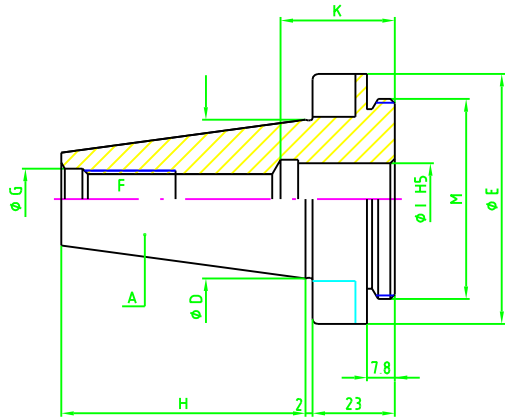

Shank adaptor ISO 30 - DIN 69871

CATS NR.	A	D	E	F	G	H	I	K	M	For CATS Heads
95335	ISO 30	31.75	60	M12	13	47.8	12	32	M4.5x1	PTH 60

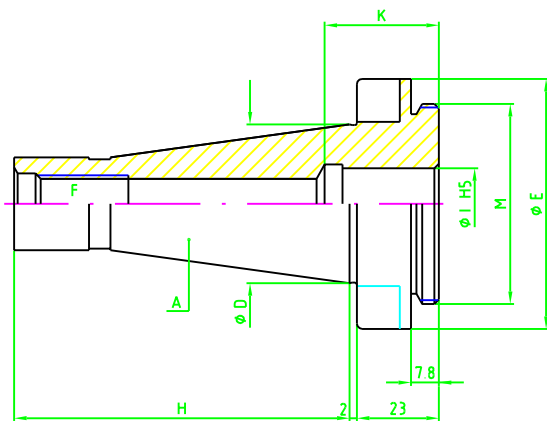

Shank adaptor ISO 30 - DIN 2080

CATS NR.	A	D	E	F	G	H	I	K	M	For CATS Heads
95331	ISO 30	31.75	60	M12	-	6.8	12	32	M4.5x1	PTH 60

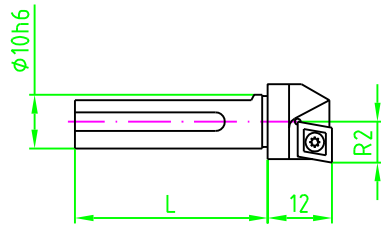

Insert holder 90°

CATS NR.	R2	L	Cap. $\phi \times L$
60501	6	20	12-26x16
60504	6	36	12-26x32
60511	8	20	8-22x36
60514	8	36	8-22x52
60521	12	20	0-14x36
60524	12	36	0-14x52

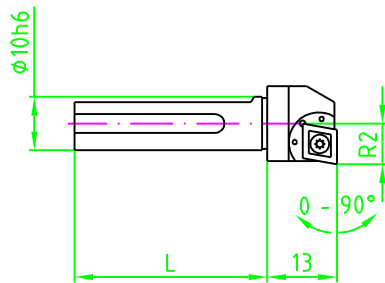

Insert holder adjustable 0°-90° complete

CATS NR.	R2	L	Cap. $\phi \times L$
60611	8	20	8-22x36
60614	8	36	8-22x52
60621	12	20	0-14x36
60624	12	36	0-14x52

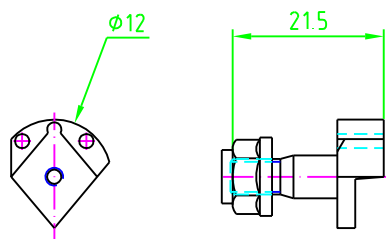

Spare part for insert holder for cutting tips CCMT 0602..

CATS NR.
03631

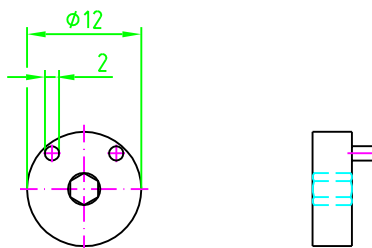

Special key for adjustable insert holder

CATS NR.
03636

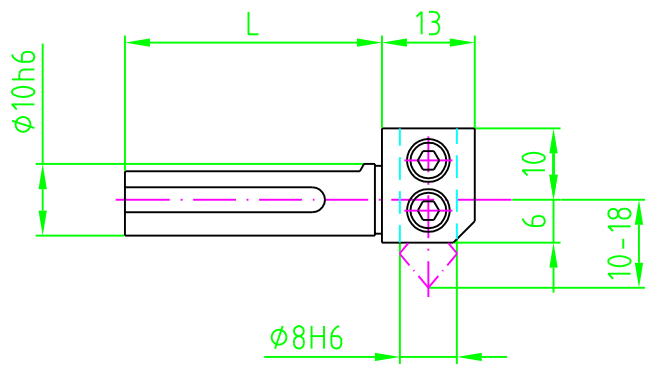

Tool holder 90°

CATS NR.	L	Cap. ϕ
60711	28	0-18x52
60714	42	0-18x64

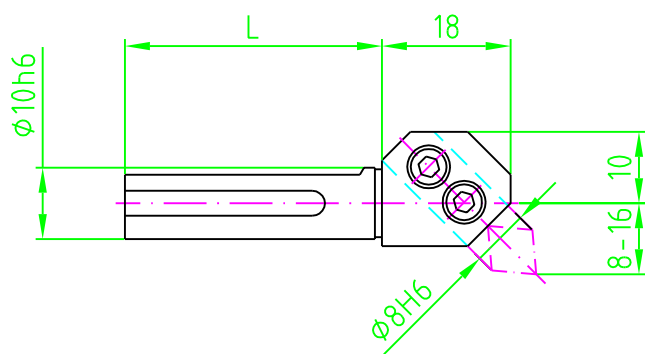

Tool holder 45°

CATS NR.	L	Cap. ϕ
60721	28	0-22x60
60724	42	0-22x74

Insert holder 90°

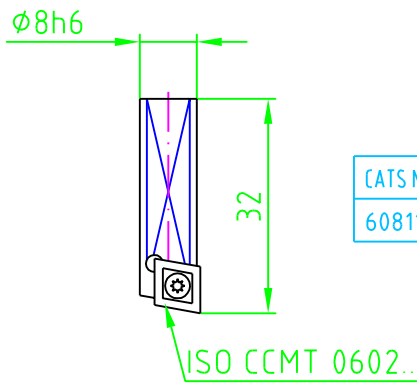

CATS NR.
60811

Insert holder 45°/90°

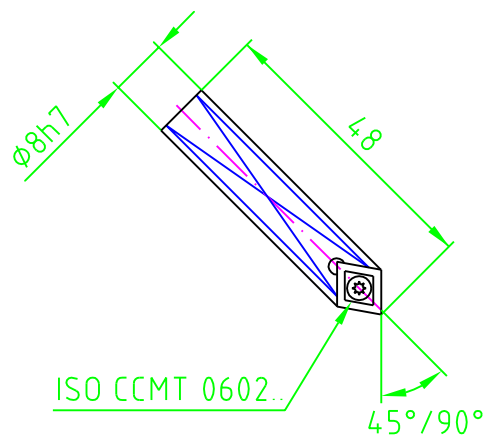

CATS NR.
60821

Insert holder 45°

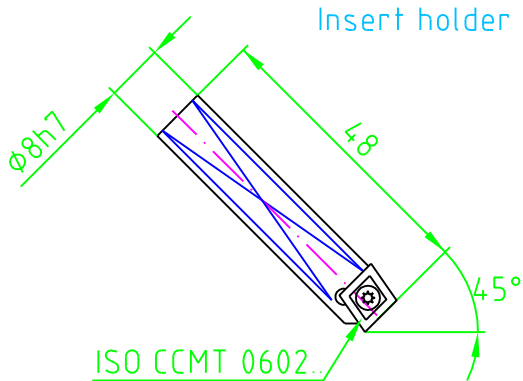

CATS NR.
60831

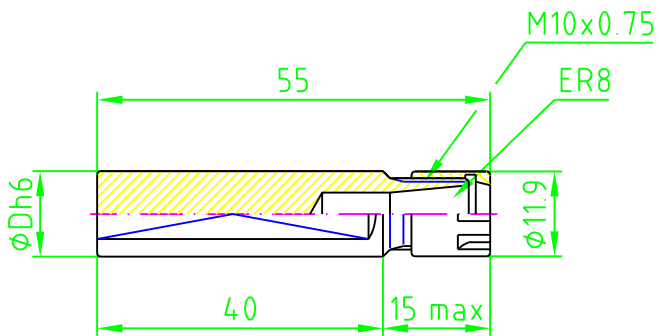

Presettable collet chuck ER8/Ø12 with nut
ER8 clamping capacity 0.5 to 5mm

CATS NR.	D
01208-01	12

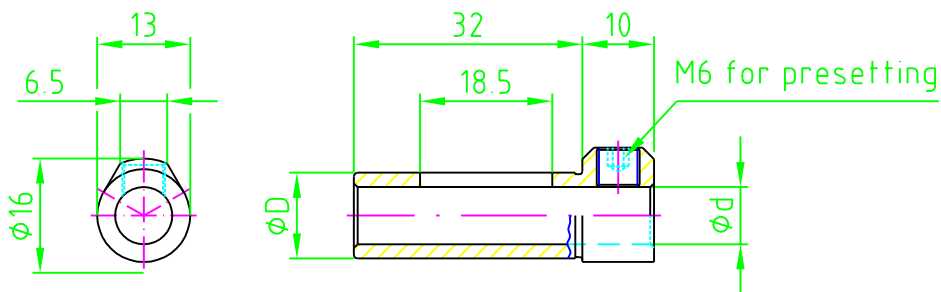

Drill holder sleeve

CATS NR.	D	d
01210-12	12	10
01208-12	12	8
01206-12	12	6

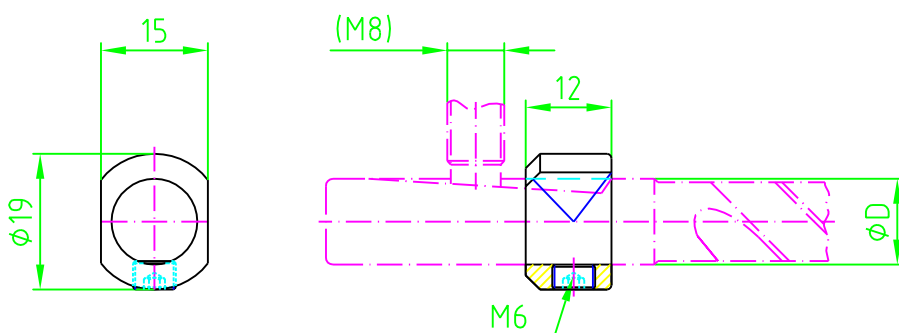

Stop ring

CATS NR.	D
01212-12	12