

The PULLEX[®] System

Crocodile

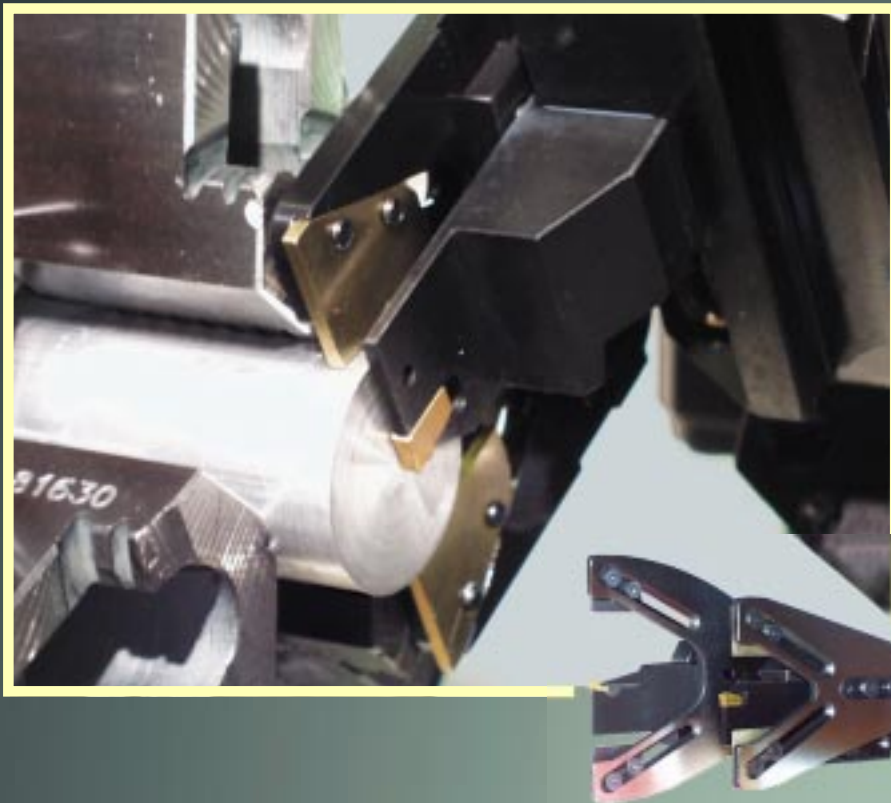

PATENT PENDING

“Don’t YOU want to do this in almost no time?”... by using a bar puller that is directly fitted on the Part-off tool shank and pulls the bar into its new cutting position simultaneously with the tool’s retraction for ATC.



MPC

The PULLEX® System

You can't possibly get the work done faster than by using this revolutionary Bar Puller, which forms a single unit together with the part-off tool shank:

- it clamps the bar instantaneously after cut-off and spindle stop
- it pulls the bar into its new position simultaneously with the tool's retraction for automatic tool change.



PULLEX' extremely compact design allows cut-off very close to the chuck jaws.



PULLEX feeds the bar within 1.5 - 2 seconds, to be compared with the job of a conventional Shortbar Feeder, which would take 10-15 seconds to execute the same operation.

Then, assuming a machining cycle time of 50 seconds for your workpiece, you'll find that:



1 day/week

- you are going to save one day each week using PULLEX
- this is a most profitable accessory for your CNC-lathe.

PULLEX needs no extra tool-post.

Shank-application: The *fixing plate* is fitted in a position between the tool shank and the upper side of the part-off tool.
The *frame* is fitted to the fixing plate.

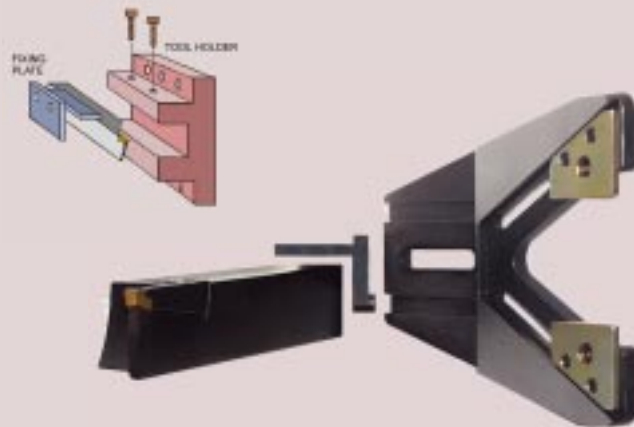

Blade-application: The *fixing plate* fit different sizes and brands of tool holders and is screwed on the tool holder.
The *frame* is fitted to the fixing plate.

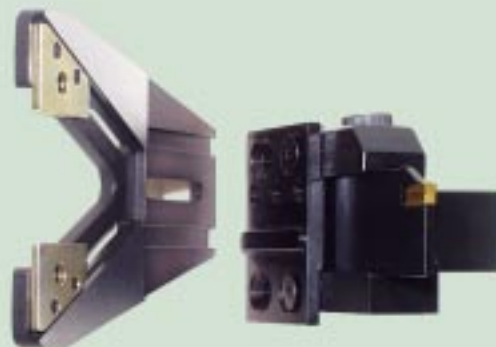

Adjustment of Pulling plates

This method for adjustment of the pulling plates is quick, accurate and eliminates errors originating from the turret and/or tool holders:

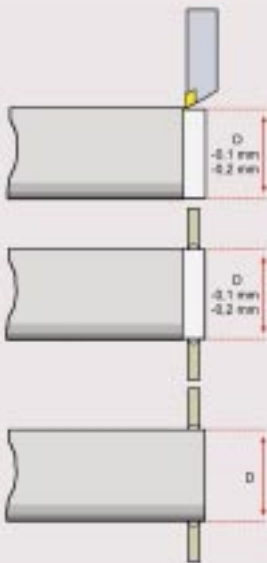

Turn a diameter of 0.1 to 0.2 mm less than the bar diameter.

Push the Pulling plates against the turned diameter to be locked in this position.

The clamping force achieved by the Pulling plates entering the bar is then amplified by the somewhat sagging bar at chuck unclamp, thus securing safe operation.

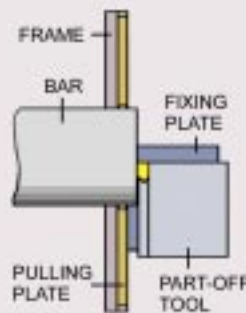
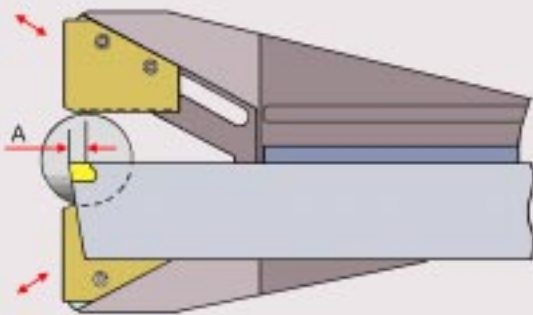

The Pulling Plates are pushed within their grooves (in the direction of the arrows) into the desired diameter within the Frame's range of 30 mm.

The Pulling plates are hardened and profile-ground for best performance.

After cut-off, the spindle is stopped and PULLEX advances a little (*see "A"*) behind the bar centre for gripping the bar.

Operating Cycle

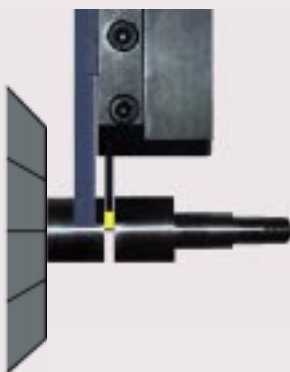

Cut-off

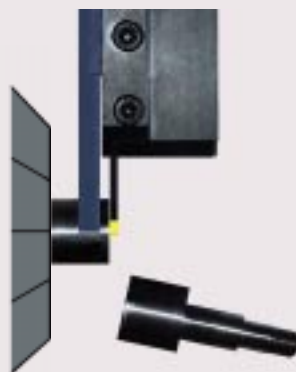

After cut-off the spindle is stopped



PULLEX advances a little behind the bar centre for gripping the bar

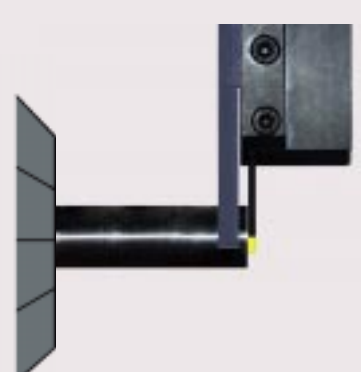

The chuck jaws are unclamped and the bar is pulled out into the new cutting position

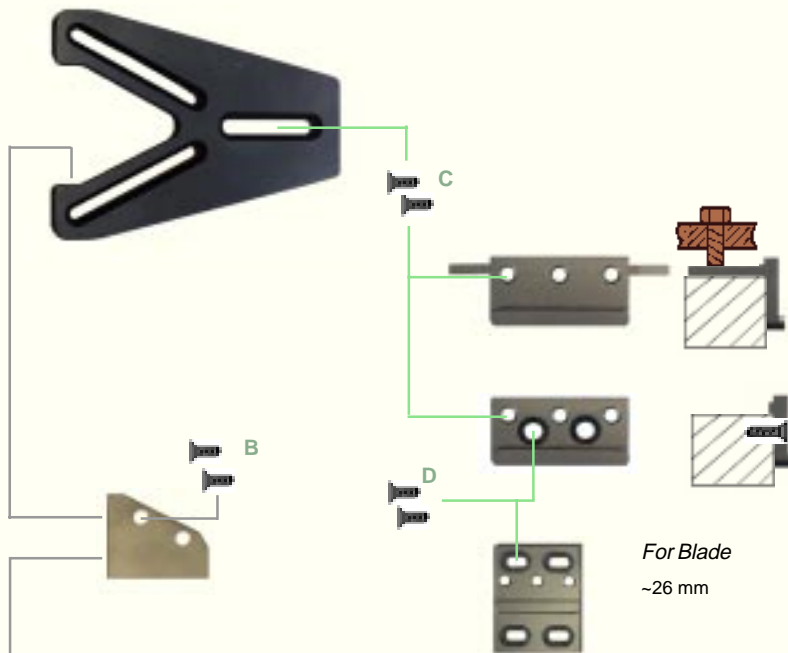

FRAME

ORDER CODE	CAPACITY
C30	1-30 mm

FIXING PLATES

ORDER CODE	DESCRIPTION
C302	For Shank To be mounted together with the part-off tool shank.

ORDER CODE	DESCRIPTION
C303	For Shank To be fitted by screws on the part-off tool shank.

ORDER CODE	DESCRIPTION
C301	For Blade ~26 mm

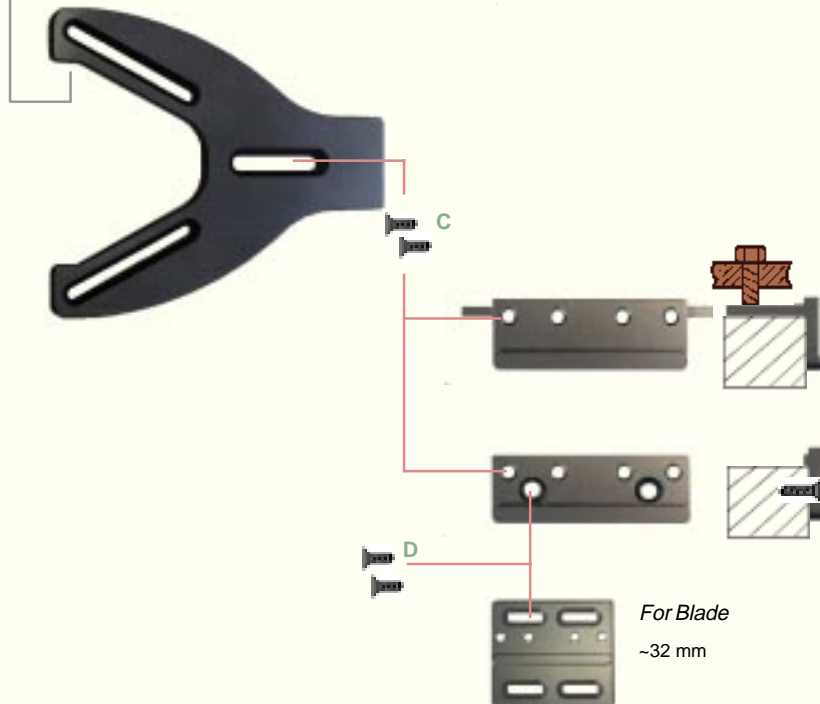

FRAME

ORDER CODE	CAPACITY
C60	30-60 mm

FIXING PLATES

ORDER CODE	DESCRIPTION
C602	For Shank To be mounted together with the part-off tool shank.

ORDER CODE	DESCRIPTION
C603	For Shank To be fitted by screws on the part-off tool shank.

ORDER CODE	DESCRIPTION
C601	For Blade ~32 mm

Spare Parts

ORDER CODE	FIG.	DESCRIPTION
PFD-1	A	Pulling Plate
M4x6	B	Screw for Pulling Plate

ORDER CODE	FIG.	DESCRIPTION
M5x8	C	Screw for Fixing Plate
M5x10	D	Screw for Fixing Plate

Remarks: The fixing plates can be used for both Left Hand and Right Hand Tools.

The different sizes of frames and fixing plates can be mixed, big frame to small fixing plate and vice versa.

Distributed by:



MPC Automation Systems AB
Box 5879, S-102 40 Stockholm, Sweden
Phone: +46 8 6670950 Fax +46 8 6670952

Visit us at <http://www.barpuller.com>